

**D-SERIES CRAWLER EXCAVATORS  
CX300D | CX350D | CX370D**

**CASE**

CONSTRUCTION



**TIER 4  
FINAL  
EU STAGE IV**

**IT'S TIME  
FOR MORE**

[www.casece.com](http://www.casece.com)

**EXPERTS FOR THE REAL WORLD  
SINCE 1842**

# HERITAGE

## A TRADITION OF INDUSTRY FIRSTS



## EXPERTS FOR THE REAL WORLD SINCE 1842

**1842** CASE is founded.

**1869** The first CASE portable steam engine - road construction is born.

**1957** The first factory - integrated loader/backhoe in the world: a CASE industry first.

**1969** CASE begins skid steer loader production.

**1992** Sumitomo becomes supplier to CASE Corporation distributing excavators ranging from 7 to 80 tons.

**1998** Global Alliance signed between CASE Corporation and Sumitomo.

**2001** CASE introduces the first of its CX excavators, powerful new "thinking machines" designed to enhance productivity through onboard intelligence features.

**2007** CX210B is awarded the «Good Design Award» by the design Academy of Japan.

**2008** CX210B wins the 18th «Energy Conservation Award» from the

Agency for Natural Resources and Energy of the Japanese Ministry of Economy.

**2011** CASE becomes the first construction equipment manufacturer to offer both selective catalytic reduction and cooled exhaust gas recirculation as solutions to meet stringent emissions standards.

**2015** CASE launches the new "D series" Tier 4 final/ EU Stage IV Crawler Excavators.

# CRAWLER EXCAVATORS D-NA

## BUILT TO LAST AND CONTROL



### HIGH RELIABILITY

Improved D-esign for D-urable performances

- The boom and arm have been re-designed according to the latest stress analysis criteria, to reduce stress points while maintaining weight optimization to ensure the best lifting performance.
- New high strength casting parts with joined hinge flanges reduce stress and increase durability.
- The undercarriage has been re-designed and re-shaped to facilitate the welding process, enhancing the reliability of the fabricated structures.
- The One-Side-Slope lower frame design reduces the time needed to clean the undercarriage.
- The thickness of the structural plates has been increased, especially in those parts where a high level of protection is required for components.

### HIGH QUALITY

Accurate, simple and robust design for high durability

- True to CASE's enviable reputation for reliability and durability, the D-series delivers leading design solutions and manufacturing quality.
- Wide choice of arm solutions, including the Heavy-Duty arm with reinforcement plate and bars on the bottom side.
- Standard Heavy-Duty boom and arm on the CX370D.



### HIGH PRECISION AND CONTROLLABILITY

Smooth control with the CASE Intelligent Hydraulic System

The proven CASE Intelligent Hydraulic System (CIHS) delivers energy savings in all cycle time phases (digging, boom up and swing, dumping).

# D-SERIES CRAWLER EXCAVATORS



## HIGH VERSATILITY

Working modes easily adapt to every work load

The familiar **working mode systems** offers 3 power modes to match different customer needs.

- A** MODE: for grading, lifting and precision work.
- H** MODE: the best balance between productivity and fuel economy.
- SP** MODE: extra speed and power for the most demanding jobs that require maximum productivity.

**Auto Power boost** automatically increases hydraulic pressure according to the operation's demands.



## FAST CYCLES

High Performance Hydraulics control

- The new electrically controlled pumps and a bigger main control valve deliver faster cycle times.
- Oil flow can be adjusted according to working needs, or increased smoothly while starting travel and boom down.
- As a result, the machine responsiveness to operation load is multiplied, resulting in cycle times up to 12% faster than the previous generation.

# PRODUCTIVITY BIGGER PERFORMANCE

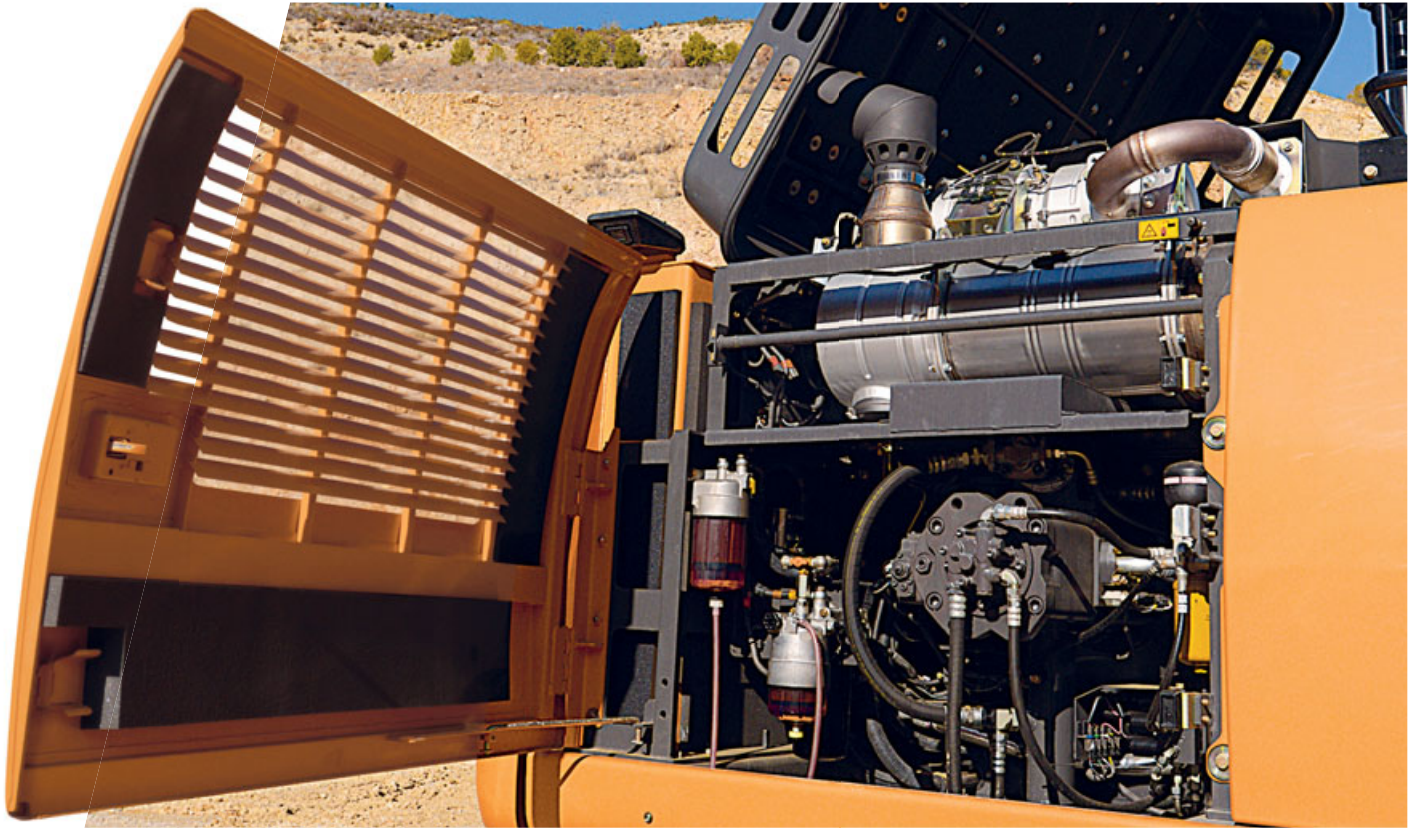

## HIGH EFFICIENCY

### Great performances with low fuel consumption

CASE advanced energy management provides solid fuel saving opportunities and lower emissions and helps to prolong the life of the machine. It consists of 5 Energy Saving controls:

- Torque control decreases main pump loads to prevent a drop in engine rpm, with improved sensitivity to control/monitor main pump loads.
- Boom Economy Control (BEC) increased fuel efficiency during boom lower and swing operations, like dump unloading.
- Swing Relief Control (SWC) carefully manages the hydraulic power distribution in slewing operations to deliver the most efficient flow and pressure.
- Spool Stroke Control (SSC) creates an automatic pressure adjustment during digging and leveling operations.
- Idle functions: the Auto Idle function lowers engine rpm after 5 seconds of lever inactivity whatever the throttle position, while the Idle Shutdown function shuts the engine down after a pre-setted time of inactivity. Both are manually switchable.



## CLEAN AND MAINTENANCE-FREE POWER

### EU STAGE IV/TIER4 FINAL compliant CASE engines

- Maintenance-free SCR and DOC-only solution.
- No Diesel Particulate Filter (DPF) or regeneration are required as no solid particles remain trapped into the system, resulting in maximum uptime and lower operating costs.
- The high engine efficiency of the latest generation, electronically controlled, high pressure common rail with multi-injection engine ensures great performance and low fuel consumption.
- CASE adds a Variable Geometry Turbocharger to ensure a fast transient response of the engine while minimizing fluid consumption”.
- The system is also very economical in its use of AdBlue, which is just 2.5%- 3% of fuel consumption. The large AdBlue tank only needs to be refilled every 10 fuel refills, so that no time is wasted.

# D-SERIES CRAWLER EXCAVATORS



## COMFORTABLE AND SAFE CAB

Ergonomic seat design and spacious cab

- Superior cab structure with ample legroom for the operator.
- Fully adjustable workstation.
- New ergonomically designed highback seat with air suspension for excellent comfort.
- Optional seat tilting adjustment and seat heater
- Top class features include 178 mm colour LED Monitor, bluetooth tuner and Radio, spacious storage compartment, 12v accessory plug, clipboard holder, mobile phone holder, warm and cool box, fuse box service connection, storage tray and ergonomic arm rest.



## SMOOTH RIDE, QUIET WORK ENVIRONMENT

Soundproof  
pressurised cab

The cushioning system lowers noise and vibration levels for the operator's ultimate comfort.



# COMFORT RULES FIRST CLASS CAB AND SEAT



# D-SERIES CRAWLER EXCAVATORS



## SAFE OPERATION

### ROPS Cab and FOPS level II

A safe working environment for the operator:

- Reinforced structure of the cab compliant with ROPS/FOPS requirements.
- Standard head protection approved to FOPS Level 2.
- Wide offering of optional front guards.
- Optional factory fitted travel alarm for greater safety on the jobsite around the machine.



## OUTSTANDING VISIBILITY

### Safety-minded cab structure

Cab designed to create a perceptibly safe and secure working environment:

- Ample glazed surface.
- Rear and side view camera.
- Unique 178 mm LED monitor with continuous camera view.
- Efficient use of space with grouped engine, cooling and after-treatment systems to provide excellent rear visibility.
- Optional LED lighting package provides a deeper and wider visibility coverage of the area around the machine when working after dark.





# SAFETY AND MAINTENANCE

## WORK SAFELY IN ALL CONDITIONS



### SAFE ACCESS TO UPPERCARRIAGE

Solid and robust platform and handrails

- Wide, robust and comfortable steps or safe access to the top of the hood.
- Solid handrail for protection on the top of the hood.
- Non slip-plates and top hood cover supported by 2 gas pistons and secured by 2 mechanical stops when open.
- A wide platform (up to 60 cm) on top of the engine compartment to work safely on the engine box.



### EASY MAINTENANCE

CASE stays «grounded»

- All filters and regular fill points are grouped for easy access.
- Engine oil change intervals set at 500 hours.
- Radiator and cooler cores mounted side by side for easy access for cleaning and more efficient cooling.
- Standard 100 l/min refueling pump with automatic cut off reduces downtime for regular fills.
- Optional hydraulic and engine oil sampling port accessible at ground level for easy oil check.
- Battery Shutdown Switch for safe maintenance on the electrical system.
- All the D-series crawler excavators feature the Extended Maintenance System (EMS) bushings, providing 1,000 hour greasing intervals on all pins except the attachment linkage.



# MAIN REASONS TO CHOOSE THE D-SERIES



## HIGH EFFICIENCY

- Energy saving system to take advantage of all fuel saving opportunities: up to 8% more fuel efficiency
- High levels of AdBlue autonomy with larger AdBlue tank and low additive consumption



## HIGH PRECISION AND CONTROLLABILITY

CASE Intelligent Hydraulic System (CIHS)  
Synonymous with high performance  
smooth control.



## HIGH RELIABILITY

Reliability and durability thanks  
to the new redesigned arm,  
boom and undercarriage.



## FAST CYCLES

- New electronically controlled hydraulic pumps
- New larger main valve





## OUTSTANDING VISIBILITY

- Wide glazed area
- Rear and side view cameras
- Large LED monitor
- Optional LED lighting package



## SMOOTH RIDE, QUIET WORK ENVIRONMENT

- Cab with cushioning system
- Low noise and vibration



## COMFORTABLE AND SAFE CAB

- Extra spacious cab
- Fully adjustable workstation
- New high back seat



## CLEAN AND MAINTENANCE-FREE POWER

- EU Stage IV/Tier4 final compliant
- No DPF
- DOC and SCR-only maintenance-free components



## SAFE OPERATION AND MAINTENANCE

- ROPS cab and FOPS level II
- Standard extended handrails and guardrails
- Optional factory fitted travel alarm
- Maintenance points grouped for easy and safe access



## HIGH VERSATILITY

- 3 available power modes to match customers needs (A, H, SP)
- Auto Power boost job-sensing hydraulic pressure increase.





## THE SCIENCE BIT

The Case SiteWatch telematics system uses a high-tech control unit mounted on each machine to collate information from that machine and from GPS satellites. This data is then sent wirelessly through the mobile communication networks to the Case Telematics Web Portal.



## SiteWatch: centralised fleet control benefits at your fingertips

### Measure your true asset availability and optimise it

- Eliminate the “phantom fleet”: SiteWatch allows to identify spare units or under loaded machines on each site.
- Become able to reallocate units where they are more needed.
- Forward Maintenance Planning is easier since the actualised working hours are always available.
- Extend the benefits of SiteWatch to the rest of your fleet: SiteWatch can be installed on the units of other brands as well.

### Challenge your Total Cost of Ownership!

- Being able to compare the fuel usage of different machine types will allow you choose the right equipment.
- Save on transport costs with planned and grouped maintenance tasks.
- Peace of mind, optimised uptime and lower repair costs: with preventive maintenance you can for example be alerted if the engine needs to be serviced and avoid a disruptive breakdown.
- Be able to compare your asset Return On Investment on different sites.
- Your equipment is used only during working hours. You can set up alerts so that you know if it is in use during the weekend or at night.
- Integrate with the programmed maintenance package, so that you can be sure every machine is at the right place at the right time.

### More Safety, Lower Insurance Premium

- Keep thieves away: dissuade them from attacking your asset because it is geo-localised. SiteWatch is hidden so that thieves can't find it quickly.
- Your fleet is used only where you decide. You can define a virtual fence and receive an email when a machine exits that perimeter.

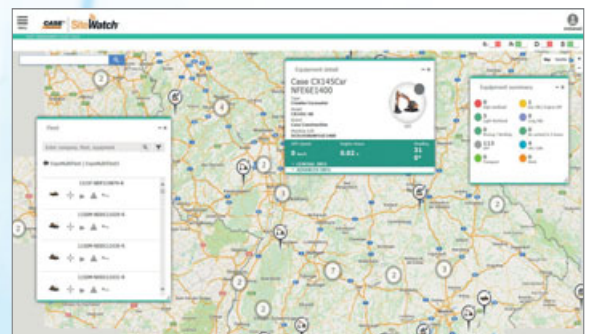

# STANDARD AND OPTIONS

## STANDARD EQUIPMENT

### ENGINE

Isuzu 6-cylinder turbo-charged diesel  
Tier 4 Final/EU stage IV Certified  
Selective Catalytic Reduction (SCR)  
Diesel Oxidation Catalyst (DOC)  
Cooled Exhaust Gas Recirculation (CEGR)  
VGT turbocharger  
Electronic fuel injection  
High pressure common rail system  
Neutral safety start  
Auto-engine warm up, emergency stop  
Glow-plug pre-heat  
Engine Protection Feature (EPF)  
Dual-stage fuel filtration  
Dual element air filter  
Remote oil filter  
Green plug oil drain  
500-hour engine oil change interval  
24-Volt system  
Battery disconnect switch  
High ambient temperature cooling package  
External Fuel and AdBlue gauges  
Fuel cooler  
Fuel filter restriction indicator  
Fuel shut-off valve  
Idle start  
Radiator, oil cooler, intercooler – protective Screen  
Refueling Pump

### FUEL ECONOMY SYSTEMS

Engine Idle/Fuel Economy System:  
Auto-idle  
One-touch idle  
Auto-idle shut-down  
Torque control  
Boom Economy Control (BEC)  
Swing Relief Control (SWC)  
Spool Stroke Control (SSC)

## OPTIONAL EQUIPMENT

### HYDRAULICS

Clamshell circuit (CX300D only)  
Low-flow circuit, proportional control  
Single acting pedal activated hammer circuit  
Single acting hammer circuit with electrical proportional control  
Pedal activated multifunction (hammer/high flow) circuit  
Multifunction (hammer/high flow) circuit with electrical proportional control

### ATTACHMENTS

Arm - 2.65/3.7 m (CX300D)  
Arm - 2.20/2.60/4.05 m (CX350D)  
HD Arm - 2.20/2.60 (CX370D)

### HYDRAULICS

Electronically controlled hydraulic pumps  
Auto power boost  
Auto travel speed change  
Selectable work modes  
Overload warning device  
ISO pattern controls  
Pre-set auxiliary pump settings  
Switch controlled auxiliary selection  
Auxiliary valve  
Hydraulic filter restriction indicator  
Oil cooler  
5,000 hour hydraulic oil change interval  
2,000 hour hydraulic filter change interval

### UPPERSTRUCTURE

ISO mirrors  
Handrail – RH access  
ISO guard rails  
Isolation mounted cab (fluid and spring)  
Lifting eyes for counterweight  
Lockable fuel cap, service doors and toolbox  
Rear and side view safety camera

### OPERATOR STATION

ROPS protection  
FOPS guard OPG level II  
Pressurized cab  
Tempered safety glass  
One-touch lock front window  
Sun visor&rain deflector  
AC/heat/defrost w/auto climate control  
Hot&coolbox, cup holder & ashtray  
Interior dome light  
Cloth covered air-suspension high-back seat  
Sliding seat – 90 mm  
Seat-belt  
Adjustable armrests

Hydraulic quick coupler provision  
Safety valves and bucket linkage with hook

### OPERATOR STATION

Front cab guard - vertical bars (OPG level 2)  
Front cab guard - vertical bars (OPG level 1)  
Front mesh screen  
Travel alarm  
AM/FM CD/radio with antenna and 2-speakers  
LED working lights  
Side view camera with LED lights (right and left)

Tilting consoles - 4-position  
Low-effort joystick controls  
Sliding cockpit 180 mm  
Auxiliary select system  
Aux-in port for personal electronics  
Multifunction LED color monitor (180 mm)  
26 selectable languages for monitor  
Anti-theft system (start code system)  
Rubber floor mat  
12-volt electric socket  
24-volt cigarette lighter  
One-piece right hand window  
Internal & external view mirrors  
Working lights (boom&upperstructure)  
Cab top working lights  
Windshield wiper / washer  
Clear (Lexan) roof window w/sunshade  
Storage compartments  
On-board diagnostic system

### ATTACHMENTS

Standard boom 6.15 m (CX300D)  
Standard boom 6.45m (CX350D)  
HD boom 6.45m (CX370D)  
Arm 3.2 m (CX300D)  
Arm 3.25 (CX350D)  
HD arm 3.25 (CX370D)  
Auxiliary pipe brackets  
Centralized lube bank  
Attachment cushion valve

### UNDERCARRIAGE

600 mm steel triple grouser shoes  
Full overlap turntable bearing tub  
Sealed link chain  
Lashing points

### UNDERCARRIAGE

700 mm steel triple grouser shoes (CX350D)  
800 mm steel triple grouser shoes (CX300D LC, CX350D, CX370D)  
900 mm steel triple grouser shoes (CX350D LC)

### TELEMATICS

Three years SiteWatch “Advanced” subscription with remote monitoring and one user’s licence

# CX D-SERIES

## CX300D

### ENGINE

Model \_\_\_\_\_ ISUZU AQ-6HK1X  
 Type \_\_\_\_\_ Water-cooled, 4-cycle diesel, 6-cylinder in line, High pressure common rail system (electric control), Turbocharger with air cooled intercooler, SCR system.  
 Number of cylinders / Displacement \_\_\_\_\_ 6 / 7,79 l  
 Bore & stroke \_\_\_\_\_ 115 mm x 125 mm  
**Rated flywheel horse power**  
 SAE J1349, ISO 9249 \_\_\_\_\_ 154 kW / 206 hp at 1800 min<sup>-1</sup>  
 ISO 14396 \_\_\_\_\_ 161 kW / 216 hp at 1800 min<sup>-1</sup>  
**Maximum torque**  
 SAE J 1349, ISO 9249 \_\_\_\_\_ 849 Nm at 1500 min<sup>-1</sup>  
 ISO 14396 \_\_\_\_\_ 880 Nm at 1500 min<sup>-1</sup>

### HYDRAULIC SYSTEM

Main pumps \_\_\_\_\_ 2 variable displacement axial piston pumps with regulating system  
 Max. oil flow \_\_\_\_\_ 2 x 243 liter/min at 1800 min<sup>-1</sup>  
**Working circuit pressure**  
 Boom/Arm/Bucket \_\_\_\_\_ 34.3 MPa - 37.3 MPa with auto power boost  
 Swing circuit \_\_\_\_\_ 30.4 MPa  
 Travel circuit \_\_\_\_\_ 34.3 MPa  
 Pilot pump \_\_\_\_\_ 27 liter/min  
 Working circuit pressure \_\_\_\_\_ 3.9 MPa  
**Boom Cylinders**  
 Bore \_\_\_\_\_ 140 mm  
 Stroke \_\_\_\_\_ 1369 mm  
**Arm Cylinder**  
 Bore \_\_\_\_\_ 150 mm  
 Stroke \_\_\_\_\_ 1650 mm  
**Bucket Cylinder**  
 Bore \_\_\_\_\_ 135 mm  
 Stroke \_\_\_\_\_ 1078 mm

### SWING

Swing Motor \_\_\_\_\_ Fixed displacement axial piston motor  
 Maximum swing speed \_\_\_\_\_ 10.0 min<sup>-1</sup>  
 Swing torque \_\_\_\_\_ 92,400 Nm

### PERFORMANCE DATA CX300D

		Arm 3.2 m	Arm 2.65 m	Arm 3.7 m
Boom length	mm	6150	6150	6150
Bucket radius	mm	1570	1570	1570
Bucket wrist action		176°	176°	176°
A Maximum reach at GRP	mm	10490	10030	10980
B Maximum reach	mm	10670	10220	11160
C Max. digging depth	mm	7100	6570	7580
D Max. digging height	mm	10050	9930	10390
E Max. dumping height	mm	7080	6930	7390
F Min. swing radius	mm	4030	3980	4080

### DIGGING FORCE (ISO 6015)

		Arm 3.2 m	Arm 2.65 m	Arm 3.7 m
Arm digging force	kN	128.4	147.0	114.3
with Auto power boost	kN	139.6	159.9	124.3
Bucket digging force	kN	175.0	175.0	175.0
with Auto power boost	kN	190.3	190.3	190.3

### FILTERS

Suction filter \_\_\_\_\_ 105 µm  
 Return filter \_\_\_\_\_ 6 µm  
 Pilot line filter \_\_\_\_\_ 8 µm

### ELECTRICAL SYSTEM

Voltage \_\_\_\_\_ 24 V  
 Alternator \_\_\_\_\_ 50 Amp  
 Starter \_\_\_\_\_ 24 V 5.0 kW  
 Battery \_\_\_\_\_ 2X12V 128 Ah/5 HR

### UNDERCARRIAGE

Travel motor \_\_\_\_\_ Variable displacement axial piston motor  
 High travel speed (Automatic travel speed shifting) \_\_\_\_\_ 5.4 km/h  
 Low travel speed \_\_\_\_\_ 3.2 km/h  
 Drawbar pull \_\_\_\_\_ 233 KN  
 Number of carrier rollers (each side) \_\_\_\_\_ 2  
 Number of track rollers (each side) \_\_\_\_\_ 9  
 Number of shoes (each side) \_\_\_\_\_ 50  
 Type of shoes \_\_\_\_\_ Triple grouser shoes  
 Grade ability \_\_\_\_\_ 70 % (35°)

### SOUND LEVEL

External guaranteed sound level  
 (EU Directive 2000/14/EC) \_\_\_\_\_ LwA 102 dB(A)  
 Operator cab sound pressure level (ISO 6396) \_\_\_\_\_ LpA 70 dB(A)

### CIRCUIT AND COMPONENT CAPACITIES

Fuel tank \_\_\_\_\_ 457 l  
 Hydraulic system \_\_\_\_\_ 300 l  
 Hydraulic tank \_\_\_\_\_ 147 l  
 Adblue tank \_\_\_\_\_ 120 l

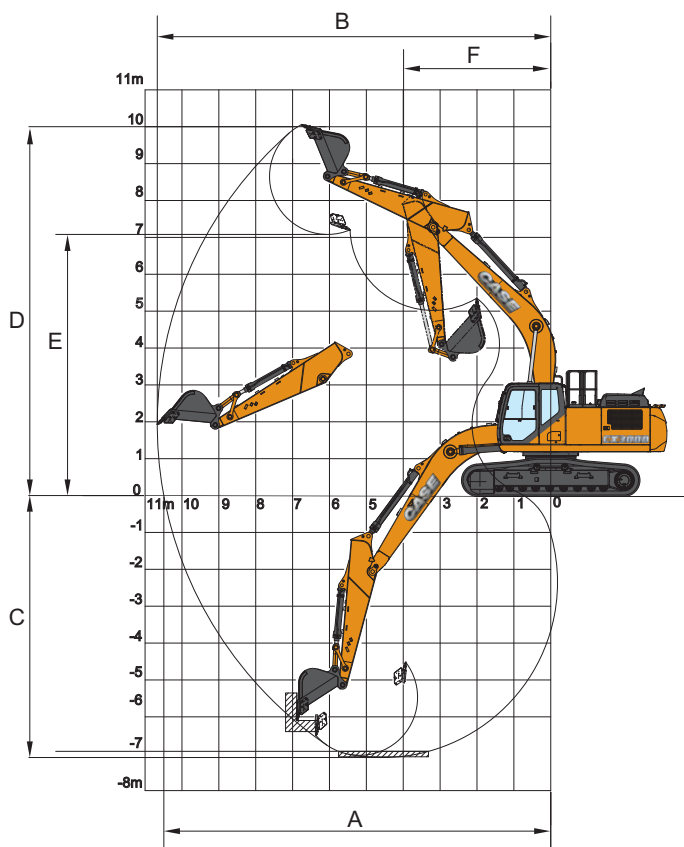

## GENERAL DIMENSIONS

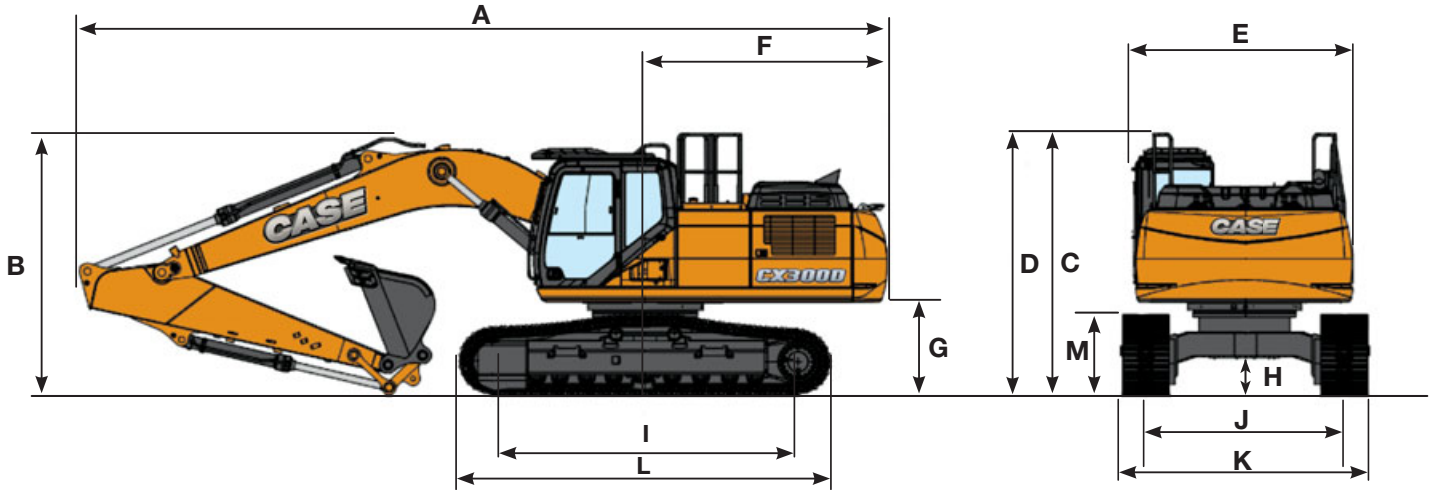

LC/NLC		Arm 3.2 m	Arm 2.65 m	Arm 3.7 m
	Overall length (without attachment)	mm	5580	5580
A	Overall length (with attachment)	mm	10510	10520
B	Overall height (to top of boom)	mm	3350	3340
C	Cab height	mm	3210	3210
D	Overall height (to top of guardrail)	mm	3420	3420
E	Upper structure overall width	mm	2890	2890
F	Swing (rear end radius)	mm	3160	3160
G	Clearance height under upper structure	mm	1190	1190
H	Minimum ground clearance	mm	460	460
I	Wheel base (Center to center of wheels)	mm	3980	3980
L	Crawler overall length	mm	4850	4850
M	Crawler tracks height	mm	1040	1040
<b>LC</b>				
		Arm 3.2 m	Arm 2.65 m	Arm 3.7 m
J	Track gauge	mm	2600	2600
K	Undercarriage overall width (with 600 mm shoes)	mm	3400	3400
<b>NLC</b>				
		Arm 3.2 m	Arm 2.65 m	Arm 3.7 m
J	Track gauge	mm	2390	2390
K	Undercarriage overall width (with 600 mm shoes)	mm	2990	2990

## WEIGHT AND GROUND PRESSURE CX300D

with 3.20 m Arm, 1.1 m<sup>3</sup> bucket, 600 mm grouser shoe, operator, lubricant, coolant, full fuel tank and FOPS protection level 2.

CX300D LC	Weight	Ground pressure
	30.000 kg	0.057 MPa
CX300D NLC	Weight	Ground pressure
	29.900 kg	0.057 MPa

Counterweight 5.100 kg

# LIFTING CAPACITY

## CX300D

Front Side	REACH									
	2.0 m		4.0 m		6.0 m		8.0 m		At max reach	

### LC UNDERCARRIAGE - Standard arm 3.2 m, 600 mm shoes, max reach 9.10 m

8.0 m								6080*	6080*	6.72	
6.0 m						6310*	5410	5690*	5270	8.12	
4.0 m			13320*	13320*	9620*	8160	7810	5270	5730*	4480	8.85
2.0 m			15990*	13640	11380*	7610	7560	5050	6130*	4180	9.1
0 m			13740*	12990	11310	7230	7370	4870	6340	4220	8.89
-2.0 m	9910*	9910*	18170*	12940	11150	7090	7310	4830	7080	4690	8.19
-4.0 m	18660*	18660*	14910*	13190	10250*	7210			8430*	6060	6.85

### LC UNDERCARRIAGE - Short arm 2.65 m, 600 mm shoes, max reach 8.65 m

8.0 m					8450*	8450*			7930*	7930*	6.1
6.0 m					8930*	8530			7290*	5820	7.61
4.0 m			14840*	14840*	10290*	8090	7790	5270	7210	4880	8.39
2.0 m					11710	7590	7580	5080	6750	4540	8.65
0 m			11770*	11770*	11350	7270	7430	4940	6910	4610	8.43
-2.0 m	10260*	10260*	17430*	13130	11270	7200			7860	5210	7.69
-4.0 m			13510*	13460	9170*	7420			8550*	7050	6.24

### LC UNDERCARRIAGE - Long arm 3.7 m, 600 mm shoes, max reach 9.58 m

8.0 m									4870*	4870*	7.37
6.0 m							6530*	5460	4560*	4560*	8.66
4.0 m					8970*	8240	7690*	5280	4570*	4090	9.35
2.0 m			16920*	13850	10850*	7640	7550	5030	4820*	3820	9.58
0 m			14380*	12940	11270	7190	7310	4820	5410*	3850	9.39
-2.0 m	8860*	8860*	18580*	12760	11050	6990	7210	4720	6390	4220	8.73
-4.0 m	15850*	15850*	15920*	12940	10870*	7050			7970*	5260	7.49
-6.0 m									8010*	8010*	4.86

### NLC UNDERCARRIAGE - Standard arm 3.2 m, 600 mm shoes, max reach 9.10 m

8.0 m									6080*	6080*	6.72
6.0 m							6310*	4970	5690*	4840	8.12
4.0 m			13320*	13320*	9620*	7480	7790	4840	5730*	4110	8.85
2.0 m			15990*	12240	11380*	6940	7550	4620	6130*	3820	9.1
0 m			13740*	11610	11280	6560	7350	4450	6320	3850	8.89
-2.0 m	9910*	9910*	18170*	11560	11130	6430	7300	4400	7070	4270	8.19
-4.0 m	18660*	18660*	14910*	11810	10250*	6550			8430*	5520	6.85

### NLC UNDERCARRIAGE - Short arm 2.65 m, 600 mm shoes, max reach 8.65 m

8.0 m					8450*	7910			7930*	7690	6.1
6.0 m					8930*	7840			7290*	5350	7.61
4.0 m			14840*	13460	10290*	7410	7770	4830	7200	4480	8.39
2.0 m					11690	6920	7570	4650	6740	4160	8.65
0 m			11770*	11700	11320	6610	7410	4510	6890	4220	8.43
-2.0 m	10260*	10260*	17430*	11750	11240	6540			7840	4750	7.69
-4.0 m			13510*	12070	9170*	6750			8550*	6430	6.24

### NLC UNDERCARRIAGE - Long arm 3.7 m, 600 mm shoes, max reach 9.58 m

8.0 m									4870*	4870*	7.37
6.0 m							6530*	5020	4560*	4360	8.66
4.0 m					8970*	7550	7960*	4850	4570*	3740	9.35
2.0 m			16920*	12430	10850*	6970	7530	4600	4820*	3490	9.58
0 m			14380*	11560	11250	6520	7300	4390	5410*	3500	9.39
-2.0 m	8860*	8860*	18580*	11380	11020	6330	7190	4290	6380	3840	8.73
-4.0 m	15850*	15850*	15920*	11560	10870*	6380			7970*	4780	7.49
-6.0 m									8010*	8010*	4.86

\* The above loads (kg) are compliant to the ISO standards and refer to the excavator equipped without bucket. The indicated loads are no more than 87% of hydraulic system lift capacity or 75% of static tipping load. Values marked with an asterisk (\*) are limited by the hydraulic lifting capacity.



## CX300D LC

### HEAVY DUTY BUCKET (DIRECT MOUNT)

CAPACITY m <sup>3</sup> (ISO7451 HEAPED)	WIDTH mm	WEIGHT kg	ARM 3.2 m	ARM 2.65 m	ARM 3.7 m
0.85	900	1039	○	○	○
1.11	1100	1143	○	○	○
1.24	1200	1233	○	○	●
1.43	1350	1311	●	●	■
1.63	1500	1460	■	●	■
1.88	1700	1568	×	■	×

### HEAVY DUTY SCOOP BUCKET (WITH CASE MULTI-FIT S COUPLER)

CAPACITY m <sup>3</sup> (ISO7451 HEAPED)	WIDTH mm	WEIGHT kg	ARM 3.2 m	ARM 2.65 m	ARM 3.7 m
0.85	900	1027	○	○	○
1.11	1100	1133	●	○	●
1.24	1200	1225	●	●	■
1.43	1350	1305	■	●	×
1.63	1500	1446	×	■	×

### ROCK BUCKET (DIRECT MOUNT)

CAPACITY m <sup>3</sup> (ISO7451 HEAPED)	WIDTH mm	WEIGHT kg	ARM 3.2 m	ARM 2.65 m	ARM 3.7 m
0.85	900	1080	○	○	○
1.11	1100	1187	○	○	○
1.24	1200	1274	○	○	●
1.43	1350	1353	●	●	■
1.63	1500	1500	■	●	■

### ROCK SCOOP BUCKET (WITH CASE MULTI-FIT S COUPLER)

CAPACITY m <sup>3</sup> (ISO7451 HEAPED)	WIDTH mm	WEIGHT kg	ARM 3.2 m	ARM 2.65 m	ARM 3.7 m
0.85	900	1068	○	○	○
1.11	1100	1177	●	○	●
1.24	1200	1265	●	●	■
1.43	1350	1347	■	■	×
1.63	1500	1486	×	■	×

## CX300D NLC

### HEAVY DUTY BUCKET (DIRECT MOUNT)

CAPACITY m <sup>3</sup> (ISO7451 HEAPED)	WIDTH mm	WEIGHT kg	ARM 3.2 m	ARM 2.65 m	ARM 3.7 m
0.85	900	1039	○	○	○
1.11	1100	1143	○	○	●
1.24	1200	1233	●	○	●
1.43	1350	1311	■	●	■
1.63	1500	1460	■	■	×

### HEAVY DUTY SCOOP BUCKET (WITH CASE MULTI-FIT S COUPLER)

CAPACITY m <sup>3</sup> (ISO7451 HEAPED)	WIDTH mm	WEIGHT kg	ARM 3.2 m	ARM 2.65 m	ARM 3.7 m
0.85	900	1027	○	○	●
1.11	1100	1133	●	●	■
1.24	1200	1225	■	●	■
1.43	1350	1305	×	■	×

### ROCK BUCKET (DIRECT MOUNT)

CAPACITY m <sup>3</sup> (ISO7451 HEAPED)	WIDTH mm	WEIGHT kg	ARM 3.2 m	ARM 2.65 m	ARM 3.7 m
0.85	900	1080	○	○	○
1.11	1100	1187	○	○	●
1.24	1200	1274	●	○	●
1.43	1350	1353	■	●	■
1.63	1500	1500	■	■	×

### ROCK SCOOP BUCKET (WITH CASE MULTI-FIT S COUPLER)

CAPACITY m <sup>3</sup> (ISO7451 HEAPED)	WIDTH mm	WEIGHT kg	ARM 3.2 m	ARM 2.65 m	ARM 3.7 m
0.85	900	1068	○	○	●
1.11	1100	1177	●	●	■
1.24	1200	1265	■	●	×
1.43	1350	1347	×	■	×

# CX D-SERIES

## CX350D - CX370D

### ENGINE

Model \_\_\_\_\_ ISUZU AQ-6HK1X  
 Type \_\_\_\_\_ Water-cooled, 4-cycle diesel, 6-cylinder in line, High pressure common rail system (electric control), Turbocharger with air cooled intercooler, SCR system.  
 Number of cylinders / Displacement \_\_\_\_\_ 6 / 7,79 l  
 Bore & stroke \_\_\_\_\_ 115 mm x 125 mm  
**Rated flywheel horse power**  
 SAE J1349, ISO 9249 \_\_\_\_\_ 200 kW / 268 hp at 1900 min<sup>-1</sup>  
 ISO 14396 \_\_\_\_\_ 210 kW / 282 hp at 1900 min<sup>-1</sup>  
**Maximum torque**  
 SAE J 1349, ISO 9249 \_\_\_\_\_ 988 N-m at 1500 min<sup>-1</sup>  
 ISO 14396 \_\_\_\_\_ 1020 N-m at 1500 min<sup>-1</sup>

### HYDRAULIC SYSTEM

Main pumps \_\_\_\_\_ 2 variable displacement axial piston pumps with regulating system  
 Max. oil flow \_\_\_\_\_ 2 x 300 liter/min at 1900 min<sup>-1</sup>  
**Working circuit pressure**  
 Boom/Arm/Bucket \_\_\_\_\_ 34.3 MPa - 37.3 MPa with auto power boost  
 Swing circuit \_\_\_\_\_ 30.4 MPa  
 Travel circuit \_\_\_\_\_ 34.3 MPa  
 Pilot pump \_\_\_\_\_ 28.5 liter/min  
 Working circuit pressure \_\_\_\_\_ 3.9 MPa  
**Boom Cylinders**  
 Bore \_\_\_\_\_ 145 mm  
 Stroke \_\_\_\_\_ 1495 mm  
**Arm Cylinder**  
 Bore \_\_\_\_\_ 170 mm  
 Stroke \_\_\_\_\_ 1748 mm  
**Bucket Cylinder**  
 Bore \_\_\_\_\_ 150 mm  
 Stroke \_\_\_\_\_ 1210 mm

### SWING

Swing Motor \_\_\_\_\_ Fixed displacement axial piston motor  
 Maximum swing speed \_\_\_\_\_ 9.7 min<sup>-1</sup>  
 Swing torque \_\_\_\_\_ 112,000 Nm

### PERFORMANCE DATA CX350D/CX370D

		Arm 3.25 m	Arm 2.20 m	Arm 2.60 m	Arm 4.05 m*
Boom length	mm	6450	6450	6450	6450
Bucket radius	mm	1680	1680	1680	1680
Bucket wrist action		173°	173°	173°	173°
A Maximum reach at GRP	mm	10980	9970	10450	11710
B Maximum reach	mm	11170	10180	10650	11900
C Max. digging depth	mm	7340	6300	6720	8140
D Max. digging height	mm	10380	9830	10280	10650
E Max. dumping height	mm	7240	6730	7110	7530
F Min. swing radius	mm	4510	4410	4440	4530

### DIGGING FORCE (ISO 6015)

		Arm 3.25 m	Arm 2.20 m	Arm 2.60 m	Arm 4.05 m*
Arm digging force	kN	164.5	225.3	194.7	140.0
with Auto power boost	kN	178.8	245.0	211.7	152.2
Bucket digging force	kN	229.7	229.7	229.7	229.7
with Auto power boost	kN	249.8	249.8	249.8	249.8

\*CX350D only

### FILTERS

Suction filter \_\_\_\_\_ 105 µm  
 Return filter \_\_\_\_\_ 6 µm  
 Pilot line filter \_\_\_\_\_ 8 µm

### ELECTRICAL SYSTEM

Voltage \_\_\_\_\_ 24 V  
 Alternator \_\_\_\_\_ 50 Amp  
 Starter \_\_\_\_\_ 24 V 5.0 kW  
 Battery \_\_\_\_\_ 2X12V 128 Ah/5 HR

### UNDERCARRIAGE

Travel motor \_\_\_\_\_ Variable displacement axial piston motor  
 High travel speed (Automatic travel speed shifting) \_\_\_\_\_ 5.5 km/h  
 Low travel speed \_\_\_\_\_ 3.3 km/h  
 Drawbar pull \_\_\_\_\_ 273 KN  
 Number of carrier rollers (each side) \_\_\_\_\_ 2  
 Number of track rollers (each side) \_\_\_\_\_ 8  
 Number of shoes (each side) \_\_\_\_\_ 48  
 Type of shoes \_\_\_\_\_ Triple grouser shoes  
 Grade ability \_\_\_\_\_ 70 % (35°)

### SOUND LEVEL

External guaranteed sound level  
 (EU Directive 2000/14/EC) \_\_\_\_\_ LwA 105 dB(A)  
 Operator cab sound pressure level (ISO 6396) \_\_\_\_\_ LpA 71 dB(A)

### CIRCUIT AND COMPONENT CAPACITIES

Fuel tank \_\_\_\_\_ 580 l  
 Hydraulic system \_\_\_\_\_ 350 l  
 Hydraulic tank \_\_\_\_\_ 175 l  
 Adblue tank \_\_\_\_\_ 152 l

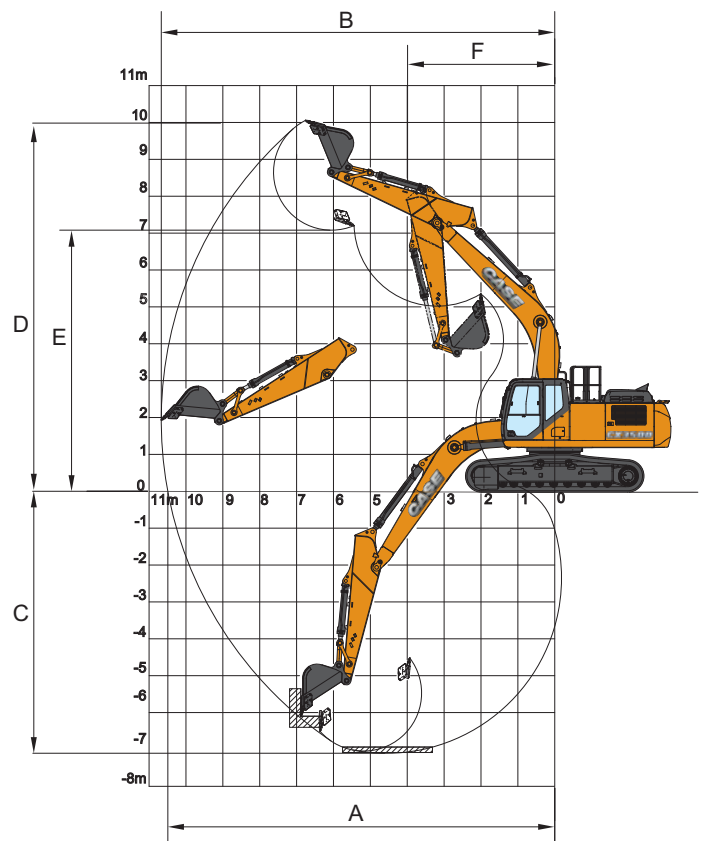

# SPECIFICATIONS

## GENERAL DIMENSIONS

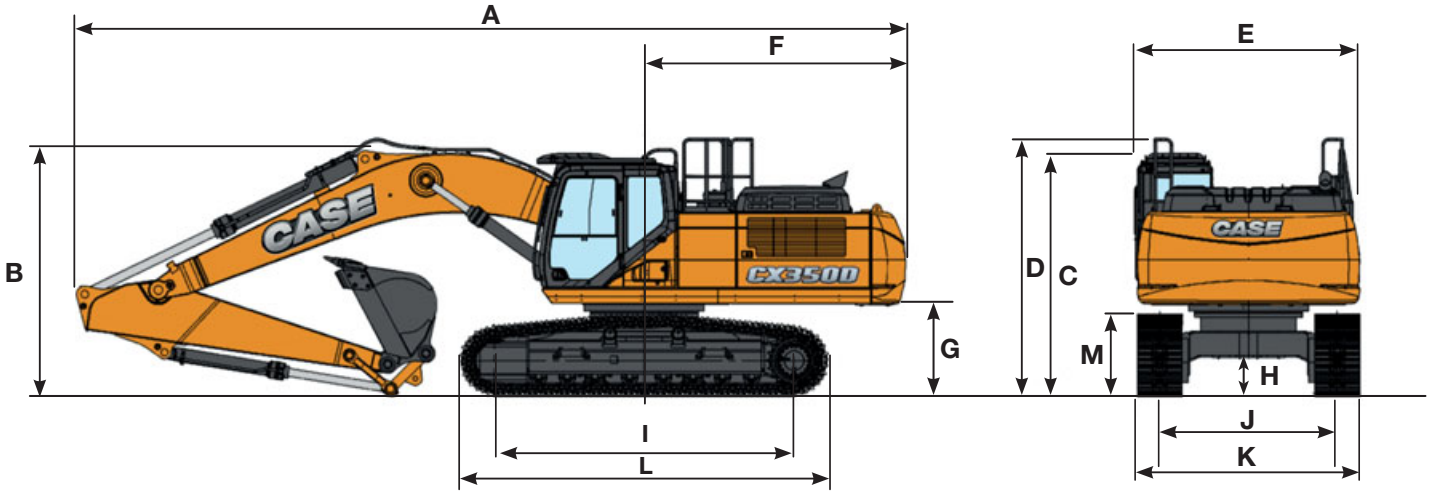

LC/NLC		Arm 3.25 m	Arm 2.20 m	Arm 2.60 m	Arm 4.05 m*	
	Overall length (without attachment)	mm	6010	6010	6010	
A	Overall length (with attachment)	mm	11170	11250	11220	11190
B	Overall height (to top of boom)	mm	3470	3620	3630	3620
C	Cab height	mm	3260	3260	3260	3260
D	Overall height (to top of guardrail)	mm	3470	3470	3470	3470
E	Upper structure overall width	mm	3030	3030	3030	3030
F	Swing (rear end radius)	mm	3550	3550	3550	3550
G	Clearance height under upper structure	mm	1210	1210	1210	1210
H	Minimum ground clearance	mm	470	470	470	470
I	Wheel base (Center to center of wheels)	mm	4040	4040	4040	4040
L	Crawler overall length	mm	4980	4980	4980	4980
M	Crawler tracks height	mm	1090	1090	1090	1090
<b>LC</b>						
		Arm 3.25 m	Arm 2.20 m	Arm 2.60 m	Arm 4.05 m*	
J	Track gauge	mm	2600	2600	2600	2600
K	Undercarriage overall width (with 600 mm shoes)	mm	3200	3200	3200	3200
<b>NLC</b>						
		Arm 3.25 m	Arm 2.20 m	Arm 2.60 m	Arm 4.05 m*	
J	Track gauge	mm	2390	2390	2390	2390
K	Undercarriage overall width (with 600 mm shoes)	mm	2990	2990	2990	2990

\*CX350D only

## WEIGHT AND GROUND PRESSURE CX350D

with 3.25 m Arm, 1.4 m<sup>3</sup> bucket, 600 mm grouser shoe, operator, lubricant, coolant, full fuel tank and FOPS protection level 2.

CX350D LC	Weight	Ground pressure
	35.800 kg	0.067 MPa
CX350D NLC	Weight	Ground pressure
	35.700 kg	0.067 MPa

Counterweight 6.400 kg

## WEIGHT AND GROUND PRESSURE CX370D

with 3.25 m Arm, 1.4 m<sup>3</sup> bucket, 600 mm grouser shoe, operator, lubricant, coolant, full fuel tank and FOPS protection level 2.

CX370D LC	Weight	Ground pressure
	38.000 kg	0.071 MPa
CX370D NLC	Weight	Ground pressure
	37.900 kg	0.071 MPa

Counterweight 7.400 kg

# LIFTING CAPACITY

## CX350D

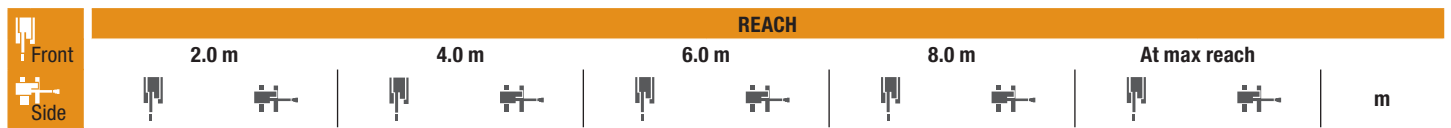

**LC UNDERCARRIAGE - Standard arm 3.25 m, 600 mm shoes, max reach 9.49 m**

Height (m)	2.0 m	4.0 m	6.0 m	8.0 m	At max reach	Reach (m)
8.0 m						7.37
6.0 m				8680*	6690	8.62
4.0 m		16200*	16200*	11230*	9950	9.29
2.0 m		14670*	14670*	13260*	9200	9.49
0 m		15610*	15610*	13850	8710	9.26
-2.0 m	12600*	12600*	20870*	15670	13670	8.56
-4.0 m	23180*	23180*	17350*	16020	12140*	7.27

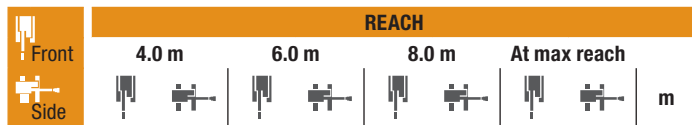

**LC UNDERCARRIAGE - Short arm 2.60 m, 600 mm shoes, max reach 8.97 m**

Height (m)	4.0 m	6.0 m	8.0 m	At max reach	Reach (m)
8.0 m				9730*	8.68
6.0 m	10230*	10230*	9390*	6480	8.05
4.0 m	11930*	6890	9480	6300	8.76
2.0 m	13710*	8970	9170	6020	8.97
0 m	13700	8580	8950	5820	8.73
-2.0 m	19540*	15690	13640	8520	7.98
-4.0 m	15300*	15300*	10760*	8830	6.57

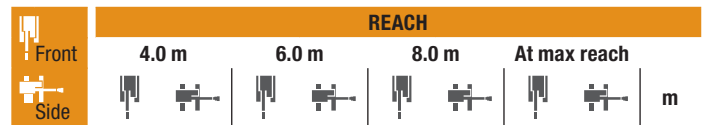

**LC UNDERCARRIAGE - S-Short arm 2.20 m, 600 mm shoes, max reach 8.50 m**

Height (m)	4.0 m	6.0 m	8.0 m	At max reach	Reach (m)
8.0 m		10650*	10480*		6.04
6.0 m		10870*	10290		7.52
4.0 m		12490*	9620	9480	8.28
2.0 m		14110*	8970	9210	8.5
0 m		13770	8650	9050	8.25
-2.0 m	18570*	15950	13530*	8660	7.45
-4.0 m	13880*	13880*			5.91

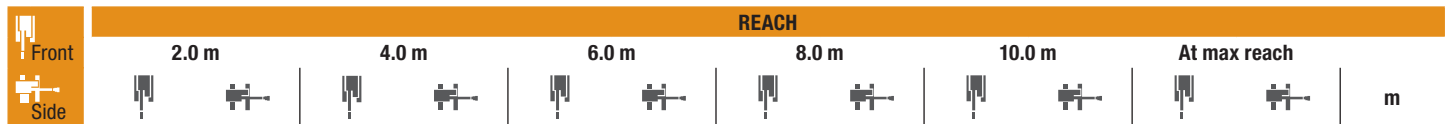

**LC UNDERCARRIAGE - Long arm 4.05 m, 600 mm shoes, max reach 10.20 m**

Height (m)	2.0 m	4.0 m	6.0 m	8.0 m	10.0 m	At max reach	Reach (m)
8.0 m				6160*	6160*		8.28
6.0 m				7660*	6760		9.42
4.0 m				9960*	9960*	8430*	10.03
2.0 m		19200*	16750	12200*	9240	9240	10.22
0 m		17890*	15490	13750	8590	8880	10
-2.0 m	11300*	11300*	21500*	15220	13420	8300	9.36
-4.0 m	18830*	18830*	18900*	15430	12980*	8340	8.19
-6.0 m		13350*	13350*	8660*	8660*		6.19

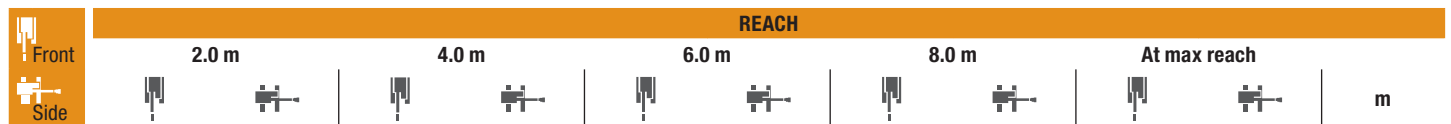

**NLC UNDERCARRIAGE - Standard arm 3.25 m, 600 mm shoes, max reach 9.49 m**

Height (m)	2.0 m	4.0 m	6.0 m	8.0 m	At max reach	Reach (m)
8.0 m						7.37
6.0 m				8680*	6190	8.62
4.0 m		16200*	16200*	11230*	9170	9.29
2.0 m		14670*	14670*	13260*	8430	9.49
0 m		15610*	14090	13820	7950	9.26
-2.0 m	12600*	12600*	20870*	14090	13640	8.56
-4.0 m	23180*	23180*	17350*	14430	12140*	7.27

\* The above loads (kg) are compliant to the ISO standards and refer to the excavator equipped without bucket. The indicated loads are no more than 87% of hydraulic system lift capacity or 75% of static tipping load. Values marked with an asterisk (\*) are limited by the hydraulic lifting capacity.

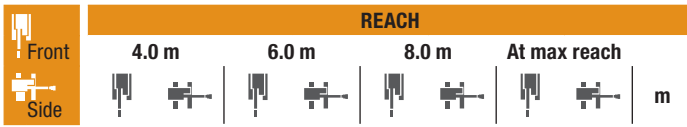

### NLC UNDERCARRIAGE

Short arm 2.60 m, 600 mm shoes, max reach 8.97 m

8.0 m						9730*	8160	6.68
6.0 m		10230*	9580	9390*	5990	8990*	5920	8.05
4.0 m		11930*	8900	9460	5810	8170	5020	8.76
2.0 m		13710*	8210	9150	5530	7710	4680	8.97
0 m		13680	7820	8940	5340	7910	4770	8.73
-2.0 m	19540*	14120	13610	7770		900	5380	7.98
-4.0 m	15300*	14570	10760*	8070		9220*	7220	6.57

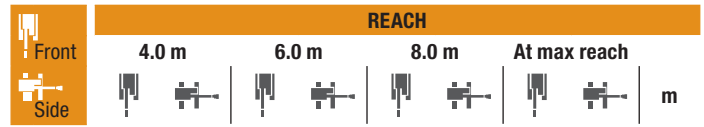

### NLC UNDERCARRIAGE

S-Short arm 2.20 m, 600 mm shoes, max reach 8.50 m

8.0 m			10650*	9690			10650*	9590	6.04
6.0 m			10870*	9500			10070*	6610	7.52
4.0 m			12490*	8850	9460	5810	8960	5510	8.28
2.0 m			14110*	8210	9190	5570	8400	5120	8.5
0 m			13740	7900	9030	5430	8660	5230	8.25
-2.0 m	18570*	14360	13530*	7910			10040	6010	7.45
-4.0 m	13880*	13880*					9700	8500	5.91

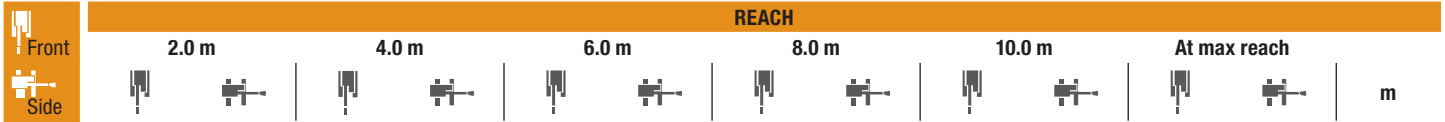

### NLC UNDERCARRIAGE - Long arm 4.05 m, 600 mm shoes, max reach 10.20 m

8.0 m						6160*	6160*			4960*	4960*	8.28	
6.0 m						7660*	6250			4710*	4650	9.42	
4.0 m					9960*	9320	8430*	5950	4950*	4070	4750*	4050	10.03
2.0 m			19200*	15120	12200*	8470	9220	5570	6520	3930	5020*	3790	10.22
0 m			17890*	13910	13720	7830	8860	5250	5620*	3800	5590*	3800	10
-2.0 m	11300*	11300*	21500*	13650	13390	7550	8680	5090			6700*	4130	9.36
-4.0 m	18830*	18830*	18990*	13860	12980*	7580	8780	5170			8510	5030	8.19
-6.0 m			13350*	13350*	8660*	8040					8150*	7720	6.19

### HEAVY DUTY BUCKET (DIRECT MOUNT)

CAPACITY m <sup>3</sup> (ISO7451 HEAPED)	WIDTH mm	WEIGHT kg	ARM 3.25 m	ARM 2.60 m	ARM 2.20 m	ARM 4.05 m
0.91	900	1213	○	○	○	○
1.19	1100	1338	○	○	○	○
1.33	1200	1439	○	○	○	●
1.54	1350	1533	●	○	○	■
1.75	1500	1666	■	●	●	■
2.03	1700	1829	■	■	■	×
2.17	1800	1894	×	■	■	×

### HEAVY DUTY SCOOP BUCKET (WITH CASE MULTI-FIT S COUPLER)

CAPACITY m <sup>3</sup> (ISO7451 HEAPED)	WIDTH mm	WEIGHT kg	ARM 3.25 m	ARM 2.60 m	ARM 2.20 m	ARM 4.05 m
0.91	900	1188	○	○	○	○
1.19	1100	1316	○	○	○	●
1.33	1200	1418	●	○	○	■
1.54	1350	1514	■	●	●	×
1.75	1500	1648	■	■	■	×
2.03	1700	1801	×	×	■	×

### ROCK BUCKET (DIRECT MOUNT)

CAPACITY m <sup>3</sup> (ISO7451 HEAPED)	WIDTH mm	WEIGHT kg	ARM 3.25 m	ARM 2.60 m	ARM 2.20 m	ARM 4.05 m
0.91	900	1254	○	○	○	○
1.19	1100	1382	○	○	○	○
1.33	1200	1480	○	○	○	●
1.54	1350	1576	●	○	○	■
1.75	1500	1706	■	●	●	■
2.03	1700	1872	■	■	■	×
2.17	1800	1939	×	■	■	×

### ROCK SCOOP BUCKET (WITH CASE MULTI-FIT S COUPLER)

CAPACITY m <sup>3</sup> (ISO7451 HEAPED)	WIDTH mm	WEIGHT kg	ARM 3.25 m	ARM 2.60 m	ARM 2.20 m	ARM 4.05 m
0.91	900	1188	○	○	○	○
1.19	1100	1316	○	○	○	●
1.33	1200	1418	●	○	○	■
1.54	1350	1514	■	●	●	×
1.75	1500	1648	■	■	■	×
2.03	1700	1801	×	×	■	×

○ Rated material density up to 2 ton/m<sup>3</sup> ● Rated material density up to 1.6 ton/m<sup>3</sup> ■ Rated material density up to 1.2 ton/m<sup>3</sup> × Not applicable

# LIFTING CAPACITY

## CX370D

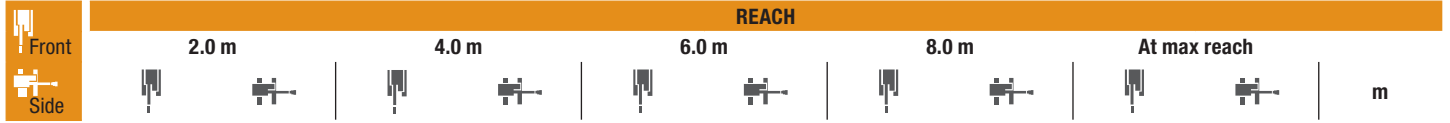

### LC UNDERCARRIAGE - Standard arm 3.25 m, 600 mm shoes, max reach 9.49 m

Height (m)	2.0 m	4.0 m	6.0 m	8.0 m	At max reach	Weight (kg)	Weight (kg)	Weight (kg)	Weight (kg)	Weight (kg)	
8.0 m									6670*	6670*	7.37
6.0 m						8430*	7070	6270*	6190	6190	8.62
4.0 m			15840*	15840*	10940*	10540	9010*	6800	6320*	5330	9.29
2.0 m			14610*	14610*	12890*	9710	9770	6450	6720*	4990	9.49
0 m			15540*	15540*	14010*	9160	9480	6180	7580*	5050	9.26
-2.0 m	12520*	12520*	20280*	16530	13800*	9000	9390	6100	8560	5600	8.56
-4.0 m	23110*	23110*	16800*	16800*	11740*	9180			8930*	7150	7.27

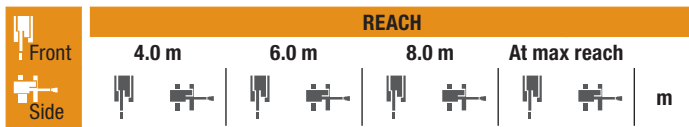

### LC UNDERCARRIAGE Short arm 2.60 m, 600 mm shoes, max reach 8.97 m

Height (m)	4.0 m	6.0 m	8.0 m	At max reach	Weight (kg)	Weight (kg)	Weight (kg)	Weight (kg)
8.0 m					9680*	9460	6.68	
6.0 m		10130*	10130*	9270*	6960	8950*	6890	8.05
4.0 m		11800*	10400	9610*	6770	8740	5860	8.76
2.0 m		13550*	9660	9790	6480	8250	5480	8.97
0 m		14290*	9240	9570	6270	8470	5590	8.73
-2.0 m	19270*	16890	13590*	9180		9550*	6320	7.98
-4.0 m	15060*	15060*	10570*	9490		9060*	8460	6.57

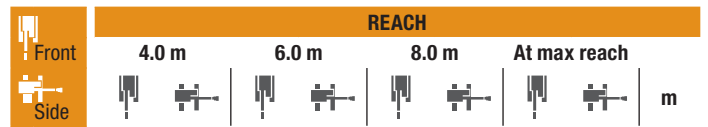

### LC UNDERCARRIAGE S-Short arm 2.20 m, 600 mm shoes, max reach 8.50 m

Height (m)	4.0 m	6.0 m	8.0 m	At max reach	Weight (kg)	Weight (kg)	Weight (kg)	Weight (kg)
8.0 m					10540*	10540*	6.04	
6.0 m		10760*	10760*			9940*	7680	7.52
4.0 m		12360*	10340	10020*	6770	9580	6420	8.28
2.0 m		13930*	9650	9830	6520	8990	5980	8.5
0 m		14390*	9310	9660	6360	9270	6120	8.25
-2.0 m	18300*	17140	13330*	9320		10250*	7040	7.45
-4.0 m	13630*	13630*				9520*	9520*	5.91

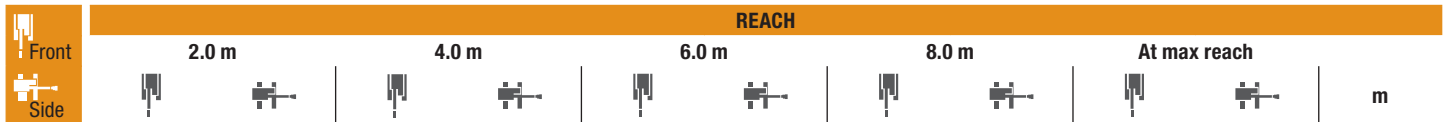

### NLC UNDERCARRIAGE - Standard arm 3.25 m, 600 mm shoes, max reach 9.49 m

Height (m)	2.0 m	4.0 m	6.0 m	8.0 m	At max reach	Weight (kg)	Weight (kg)	Weight (kg)	Weight (kg)	Weight (kg)	
8.0 m									6670*	6670*	7.37
6.0 m						8430*	6550	6270*	5720	5720	8.62
4.0 m			15840*	15840*	10940*	9720	9010*	6280	6320*	4910	9.29
2.0 m			14610*	14610*	12890*	8900	9750	5930	6720*	4590	9.49
0 m			15540*	14860	14010*	8370	9460	5660	7580*	4640	9.26
-2.0 m	12520*	12520*	20280*	14870	13800*	8210	9370	5590	8550	5140	8.56
-4.0 m	23110*	23110*	16800*	15260	11740*	8380			8930*	6560	7.27

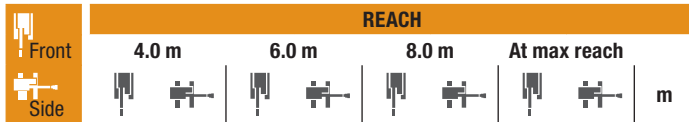

### NLC UNDERCARRIAGE Short arm 2.60 m, 600 mm shoes, max reach 8.97 m

Height (m)	4.0 m	6.0 m	8.0 m	At max reach	Weight (kg)	Weight (kg)	Weight (kg)	Weight (kg)
8.0 m					9680*	8760	6.68	
6.0 m		10130*	10130*	9270*	6440	8950*	6370	8.05
4.0 m		11800*	9580	9610*	6250	8730	5400	8.76
2.0 m		13550*	8860	9770	5960	8230	5050	8.97
0 m		14290*	8450	9550	5760	8450	5140	8.73
-2.0 m	19270*	15220	13590*	8390		9550*	5810	7.98
-4.0 m	15060*	15060*	10570*	8690		9060*	7770	6.57

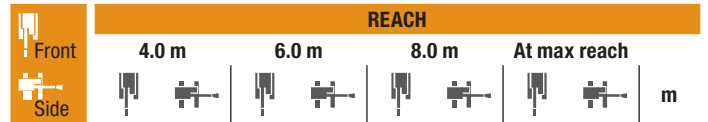

### NLC UNDERCARRIAGE S-Short arm 2.20 m, 600 mm shoes, max reach 8.50 m

Height (m)	4.0 m	6.0 m	8.0 m	At max reach	Weight (kg)	Weight (kg)	Weight (kg)	Weight (kg)
8.0 m					10540*	10400	6.04	
6.0 m		10760*	10210			9940*	7110	7.52
4.0 m		12360*	9520	10020*	6260	9560	5930	8.28
2.0 m		13930*	8850	9810	6000	8970	5510	8.5
0 m		14390*	8510	9640	5850	9250	5640	8.25
-2.0 m	18300*	15470	13330*	8520		10250*	6470	7.45
-4.0 m	13630*	13630*				9520*	9150	5.91

\* The above loads (kg) are compliant to the ISO standards and refer to the excavator equipped without bucket. The indicated loads are no more than 87% of hydraulic system lift capacity or 75% of static tipping load. Values marked with an asterisk (\*) are limited by the hydraulic lifting capacity.

## CX370D LC

### HEAVY DUTY BUCKET (DIRECT MOUNT)

CAPACITY m <sup>3</sup> (ISO7451 HEAPED)	WIDTH mm	WEIGHT kg	ARM 3.25 m	ARM 2.60 m	ARM 2.20 m
0.91	900	1213	○	○	○
1.19	1100	1338	○	○	○
1.33	1200	1439	○	○	○
1.54	1350	1533	○	○	○
1.75	1500	1666	●	●	○
2.03	1700	1829	■	●	●
2.17	1800	1894	■	■	●

### HEAVY DUTY SCOOP BUCKET (WITH CASE MULTI-FIT S COUPLER)

CAPACITY m <sup>3</sup> (ISO7451 HEAPED)	WIDTH mm	WEIGHT kg	ARM 3.25 m	ARM 2.60 m	ARM 2.20 m
0.91	900	1188	○	○	○
1.19	1100	1316	○	○	○
1.33	1200	1418	○	○	○
1.54	1350	1514	●	●	○
1.75	1500	1648	■	●	●
2.03	1700	1801	×	■	■
2.17	1800	1867	×	■	■

### ROCK BUCKET (DIRECT MOUNT)

CAPACITY m <sup>3</sup> (ISO7451 HEAPED)	WIDTH mm	WEIGHT kg	ARM 3.25 m	ARM 2.60 m	ARM 2.20 m
0.91	900	1254	○	○	○
1.19	1100	1382	○	○	○
1.33	1200	1480	○	○	○
1.54	1350	1576	○	○	○
1.75	1500	1706	●	●	○
2.03	1700	1872	■	●	●
2.17	1800	1939	■	■	●

### ROCK SCOOP BUCKET (WITH CASE MULTI-FIT S COUPLER)

CAPACITY m <sup>3</sup> (ISO7451 HEAPED)	WIDTH mm	WEIGHT kg	ARM 3.25 m	ARM 2.60 m	ARM 2.20 m
0.91	900	1207	○	○	○
1.19	1100	1338	○	○	○
1.33	1200	1438	●	○	○
1.54	1350	1534	●	●	○
1.75	1500	1665	■	●	●
2.03	1700	1821	×	■	■
2.17	1800	1889	×	■	■

## CX370D NLC

### HEAVY DUTY BUCKET (DIRECT MOUNT)

CAPACITY m <sup>3</sup> (ISO7451 HEAPED)	WIDTH mm	WEIGHT kg	ARM 3.25 m	ARM 2.60 m	ARM 2.20 m
0.91	900	1213	○	○	○
1.19	1100	1338	○	○	○
1.33	1200	1439	○	○	○
1.54	1350	1533	●	○	○
1.75	1500	1666	■	●	●
2.03	1700	1829	■	■	●
2.17	1800	1894	×	■	■

### HEAVY DUTY SCOOP BUCKET (WITH CASE MULTI-FIT S COUPLER)

CAPACITY m <sup>3</sup> (ISO7451 HEAPED)	WIDTH mm	WEIGHT kg	ARM 3.25 m	ARM 2.60 m	ARM 2.20 m
0.91	900	1188	○	○	○
1.19	1100	1316	○	○	○
1.33	1200	1418	●	○	○
1.54	1350	1514	■	●	●
1.75	1500	1648	×	■	●
2.03	1700	1801	×	×	■
2.17	1800	1867	×	×	■

### ROCK BUCKET (DIRECT MOUNT)

CAPACITY m <sup>3</sup> (ISO7451 HEAPED)	WIDTH mm	WEIGHT kg	ARM 3.25 m	ARM 2.60 m	ARM 2.20 m
0.91	900	1254	○	○	○
1.19	1100	1382	○	○	○
1.33	1200	1480	○	○	○
1.54	1350	1576	●	○	○
1.75	1500	1706	■	●	●
2.03	1700	1872	■	■	■
2.17	1800	1939	×	■	■

### ROCK SCOOP BUCKET (WITH CASE MULTI-FIT S COUPLER)

CAPACITY m <sup>3</sup> (ISO7451 HEAPED)	WIDTH mm	WEIGHT kg	ARM 3.25 m	ARM 2.60 m	ARM 2.20 m
0.91	900	1207	○	○	○
1.19	1100	1338	○	○	○
1.33	1200	1438	●	○	○
1.54	1350	1534	■	●	●
1.75	1500	1665	×	■	●
2.03	1700	1821	×	×	■

www.casece.com

**EXPERTS FOR THE REAL WORLD**  
**SINCE 1842**

**CASE**  
CONSTRUCTION



Form No. 20140GB - Printed in Italy - MediaCross Firenze - 04/16

**CNH INDUSTRIAL  
DEUTSCHLAND GMBH**  
Case Baumaschinen  
Benzstr. 1-3 - D-74076 Heilbronn  
DEUTSCHLAND

**CNH INDUSTRIAL FRANCE, S.A.**  
16-18 Rue des Rochettes  
91150 Morigny-Champigny  
FRANCE

**CNH INDUSTRIAL - UK**  
First Floor, Barclay Court 2,  
Heavens Walk,  
Doncaster - DN4 5HZ  
UNITED KINGDOM

**CNH INDUSTRIAL - SOUTH AFRICA**  
Waterfall Business Park  
Bekker Street, Howick Close  
1685 Midrand - Johannesburg  
REPUBLIC OF SOUTH AFRICA

**CNH INDUSTRIAL  
MAQUINARIA SPAIN, S.A.**  
Avda. José Gárate, 11  
28823 Coslada (Madrid)  
ESPAÑA

**CNH INDUSTRIAL ITALIA SPA**  
Strada di Settimo, 323  
10099 San Mauro Torinese (TO)  
ITALIA

**CASE CUSTOMER CENTRE  
PARIS**  
RN 330 - Penchard  
77122 - Monthyon  
FRANCE

**CNH INDUSTRIAL - MIDDLE EAST**  
DAFZA - Dubai Airport Free Zone  
West Wing 4 B, Office 642  
P.O. Box 54588, Dubai,  
UNITED ARAB EMIRATES

**NOTE:** Standard and optional fittings can vary according to the demands and specific regulations of each country. The illustrations may include optional rather than standard fittings - consult your Case dealer. Furthermore, CNH Industrial reserves the right to modify machine specifications without incurring any obligation relating to such changes.

Conforms to directive 2006/42/EC

**CASE**  
**00800-2273-7373**

The call is free from a land line.  
Check in advance with your Mobile Operator if you will be charged. Toll free number not available from all calling areas.