

MLT 625



AGRICULTURAL HANDLING solution



 **MANITOU**

www.manitou.com

A COMMITMENT TO FARMING



MANITOU have been closely associated with agriculture for more than 20 years, we know your business is both **everchanging and demanding**, we fully understand your needs so you can be sure you'll be able to find the MANITOU you need from our extensive farming range.

The MLT 625 rough terrain telescopic handler is a machine ideally suited for you and has been developed with ultra compact dimensions. It will enable you to carry out all your **farm handling** operations: animal feed, bale handling, bulk loading and unloading.

Dairy and livestock farms, nurseries, poultry or any operation where space is restricted, you will appreciate all the qualities of this machine. More than just a handling solution, MANITOU offers you a machine which both looks good and is comfortable to use: the interior and exterior have incorporated the latest modern design technology.

The MLT 625 includes the benefits and features of recent innovations from the MANITOU design team: JSM^{®*}, new cab and ECS^{**}, enabling you to work in comfort and to **maximum productivity**.

When you choose MANITOU, you can rely on a machine with a high level of performance. You also benefit from all the services offered by your local MANITOU dealer: After-sales service, maintenance contracts, on-site repairs, personalised leasing and finance solutions.

Like you, we are dedicated to agriculture.



* Joystick Switch and Move, patent applied for by MANITOU BF

** Easy Connect System: hydraulic changeover of the accessory line, standard on the Premium version



A unique farm **solution**



PERFORMANCE ON YOUR FARM

1 m 81 x 2 m:

ultra compact dimensions to easily access the most confined spaces.

18 inches:

Agricultural profile tyres... specifically for farming applications!

38 cm:

Ground clearance to get you out of any situation.



Compact ?... Super Compact !

Super compact dimensions to access the most restricted area. At less than 2m high and 1.81 m wide, the MLT 625 can easily enter your buildings and operates in areas which are inaccessible to other machinery.



Goes anywhere

In addition to its ground clearance of 38 cm, the MLT 625 is fitted with 18" agricultural profile tyres. The excellent traction and grip allows the machine to operate on all types of terrain. You can work in any situation and versatility becomes part of your daily life.



COMFORTABLE WORKING ENVIRONMENT

A spacious and ergonomically designed cab

A **compact machine** with a **spacious cab**: the driving position has been **designed with operator comfort in mind**. Low noise levels and improved driver productivity is achieved due to the full soundproofing of the cab (only 76 dB) and engine compartment areas.

The dashboard has a **digital** display which gives all the information you need during your working day: hour meter, speed, travel direction, wheel alignment indicator, maintenance reminder...

Designed to increase comfort!



Intuitive controls

Exclusive to MANITOU, the **JSM**[®] single lever allows you to operate in complete safety and carrying out every movement with one hand:

- raise and lower the boom,
- extend and retract the boom,
- tilt and crowd the bucket,
- hydraulically operate the accessories,,
- shift low gear/fast gear,
- forward and reverse.



You always keep one hand on the steering wheel to maintain full control of your MLT.



Choose your finish

Our standard machine already meets many expectations, but since every customer is unique, you have 2 levels of finish to choose from:

 **CLASSIC**  **PREMIUM**

		
Carriage + forks	●	●
Radiator auto cleaning system	●	●
Automatic parking brake	●	●
Rear-view mirror	●	●
Air conditioning	○	●
Easy Connect System	○	●
Mechanical cloth seat	●	–
Pneumatic cloth seat	○	●
Radio player	●	–
Autoradio CD/MP3	○	●
Boom suspension	○	○
Eco-mode 25 kph	○	○
Eco-mode 30 kph	○	○
Manual accelerator	○	○
Continuous flow	○	○
Flow control system	○	○
Hydraulic locking (accessories)	○	○
Electric prewriting at the boom head	○	○
Free flow return	○	○
Work lights on the boom	○	○
Electrical rear windscreen defrost	○	○
Windscreen Guard	○	○

● Standard ○ Options – Not available



**Optimising
the power of
your engine**

POWER AND PERFORMANCE

Each telehandler must have a **suitable power unit** to give you the best engine/machine torque: too little power and you lose efficiency; too much power could increase consumption to no effect.

The Kubota 4 cylinder Turbo 75 HP (55.4 kW), 3.3 l meets the ST3B / FT4* anti-pollution guidelines. The MLT 625 is perfectly adapted with a power/weight ratio giving you exceptional performance and fuel consumption from the fully flexible hydrostatic transmission.

Aware of the importance of the cost of ownership and protection of the environment, MANITOU has developed an eco-mode. This system allows up to 20% fuel saving in travel mode, while reducing the noise by 2 db, with no impact on performance.

In application or in travel mode, the flexibility and precision of the 2-speed mechanical gearbox allows you to travel at speeds up to 30 kph.**

* FT4 : Final Tier 4

** 30 kph : available in option, depends on road regulations

75 HP:

The 75 HP of your MLT 625 gives you efficient fuel consumption thanks to its ideal power/weight ratio.

2 speeds:

Flexibility and precision are important factors with the 2-speed hydrostatic transmission allowing change on the move and gear change on the JSM®.

Fast work cycles for
maximum efficiency



21 seconds:

Your MLT 625 allows you to carry out a full work cycle in only 21 seconds.

4x4x4:

4 wheel drive and 4 wheel steer = manoeuvrability for maximum agility

90 l/min:

The hydraulic gear pump, combined with the JSM[®], delivers a maximum flow rate of 90 l/min for easy and accurate movements.

YOU WILL HAVE TIME TO SPARE

Save yourself time to concentrate on what matters - that's MANITOU's philosophy when it comes to handling. Fast working cycles and driver comfort are good examples.

The 90 l/235 bar hydraulic gear pump provides high flow hydraulic performance for a machine of its class. Combined with JSM® it enables you to achieve fast working cycles.

For **maximum productivity** MANITOU offers you a machine which is simple to use. Ergonomically designed JSM® control, with all functions perfectly placed for total precision and efficiency for all your handling duties.

Manoeuvrability is your priority! The MLT 625 can fully access the majority of your working environment. With four wheel steering, the compact dimensions of your machine and its excellent turning circle makes it easy to fulfil your daily tasks.



Attachments adapted to your activity

Your productivity and safety depends on attachments that are tailored to your handler's specifications. When developing our machines we qualify the **attachment** that will be able to give you optimal **performance** and that comply with the norms in force. Choose a MANITOU approved accessory, the best choice for your MLT!

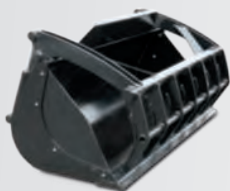

Multifunction grab bucket

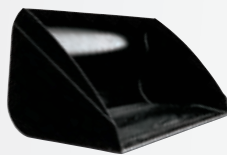

Light Material Bucket



Pickup Sweeper



Feeding Bucket



Bale Clamp Classic

A REAL **KNOW-HOW**

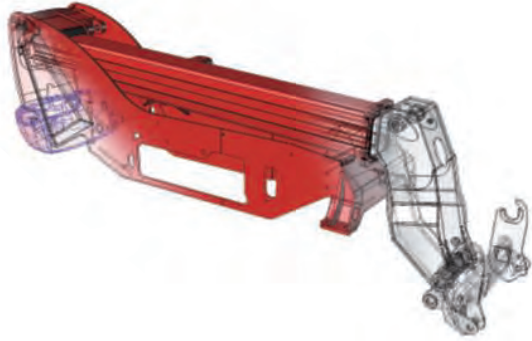

Our **design department**, employing more than 200 engineers and technicians, have specialised in the design of agricultural telehandlers **for more than 20 years**. With more than 50 registered patents, our knowledge and expertise with regard to the structure of the machine offers you reliability and durability. A fully comprehensive testing procedure and «best practice» methods are applied to ensure quality manufacturing at all levels, utilising all the latest modern technology. Specialists in agriculture, MANITOU develop their product range with the customer in mind, selecting components to suit the most arduous farm handling needs, your machine like the MANITOU company is **100% dedicated to agriculture**: the tyres, transmission and even the cooling system have been logically chosen and assembled.

YOU ARE **PROTECTED**

Your working environment must be a safe area.

The excellent **stability** of the MLT 625 combined with the aggravating movement device allows you to handle loads up to **2.5 tonnes** with complete confidence.

Your **safety** is further enhanced by the **operator presence detector** located in the seat. Travel movements are only allowed when you are sitting in the driving seat.

The cab has been especially designed to protect you. Satisfying **ROPS/FOPS*** requirements, for roll over protection and falling objects protection.

360° all round visibility gives you unrivalled vision providing a safe working environment.

The **automatical parking brake** guarantees the immobility of the machine as soon as you return to neutral.

* ROPS: rollover protection structure
FOPS: falling objects protection structure



MANITOU SERVICES



Tailor-made finance to make the best use of your funds

You can plan the purchase of your forklift with peace of mind by using MANITOU* financing opportunities.

You will have simple solutions adapted to your needs and seasonal requirements. If you want to make a rapid investment, consider asking us for a personalised proposal to take your situation into account.

* MANITOU Finance solutions are available in certain countries.

MANITOU maintenance contract

2 levels of maintenance adapted to your needs.

You are sure of:

- equipment always in good working condition
- a reduction of repair costs as a result of regular servicing
- authentic standardised services

- Labour
- Attendance costs



- Labour
- Attendance costs
- Parts and lubricants



Extension of guarantee



With MANIPLUS, you can take out an extension of guarantee of 12 or 24 months.

EASY MANAGER

A simple and flexible system for fleet management (with or without geolocation) to provide optimum service from your machines. EASY MANAGER gives you:

- real-time materials management
- simple and easy way of managing your machinery activity and maintenance
- maximise your asset and safeguard your equipment



MANITOU spare parts

Utilising genuine MANITOU spare parts is sure to prolong the best performance capability of your machine. Your MANITOU dealer has access to a stock of 70,000 part numbers, available in 24 hours in Europe (48 hours outside Europe).



TOGETHER, LET'S REDUCE OUR CARBON FOOTPRINT



The material handling sector has not yet got a normalised cycle to measure the trucks' energy consumption. Manitou Group clearly shows its commitment to transparency by establishing an internal protocol, accessible to all, that can reveal its own measures of consumption (l/h) and CO2 emissions (kg/h). To provide the highest reliability, the data is checked and approved by an independent body, UTAC* specialized in the registration of vehicles and equipment.

SUSTAINABLE SOLUTIONS

To be THE material handling reference is to commit to innovate to offer you safe, efficient and sustainable solutions today and tomorrow.

TEST PROTOCOL

Consumption measurements are performed on four representative activities of a telescopic forklift: handling, bulk loading, idle and road work.



TOGETHER

Manitou Group would like to accompany you in reducing your trucks fuel consumption to help cut back your carbon footprint.

APPROVED PROCEDURES

To validate orientations adopted by the Group in terms of fuel consumption, we wanted to validate our procedures via a recognised external body.

INFORM

We have developed information and awareness tools (product labels, iPad simulator...) to inform you about our trucks' fuel consumption and emissions.



Calculate your fuel consumption:
<http://reduce.manitou.com>



*UTAC: Technical Union for the Automobile, Motorcycle and Cycle Industries performs official duty cycles in the automotive sector. UTAC is the only French Technical Service notified to the European Commission and the UNO for fuel consumption.

MLT 625-75 H

Lifting	
Max. capacity	2500 kg
Max. lifting height	5.90 m
Break-out force with bucket (ISO 8313)	4205 daN
Unladen time	
Lifting	7.3 s
Lowering	4.95 s
Extension	5.2 s
Retraction	3.7 s
Crowd	3.2 s
Dump	3.2 s
Tyres	12.0-18 12 PR
Service brake	hydraulic oil immersed multi-disc braking
Engine	
KUBOTA STAGE III B / FINAL TIER 4	
Type	V3307-DI-T-E4B
Cubic capacity	4 cylinders - 3331 cm ³
Power	75 HP/55.4 kW Turbo
Max. torque	265 Nm
Injection	direct
Cooling	water
Laden drawbar pull	3240 daN
Transmission	
hydrostatic	
Reversing shift	electro-hydraulic
Number of gears (forward/reverse)	2/2
Max. travel speed (may vary according to applicable regulations)	30 kph
Steering mode	4 wheel steer - 3 Steering Modes
Controls	
JSM® Joystick multi-fonction Load Limiter Cut off system - EN15000 Norm	
Hydraulics	
Pump	gear type with priority valve 90 l/min - 235 bar
Capacities	
Cooling system	12 l
Engine oil	11.2 l
Hydraulic oil	115 l
Fuel	63 l
Unladen weight (with forks)	4932 kg
Dimensions	
C. Front wheel centre to carriage	0.99 m
B. Wheelbase	2.30 m
I. Rear wheel centre to rear face	0.60 m
D. Overall length to carriage	3.89 m
G. Ground clearance	0.38 m
J. Overall width of cab	0.79 m
F. Inside tyre width	1.50 m
W. Overall width	1.81 m
U1. Overall height	2.00 m
Standard forks (length x width x thickness)	1200 x 125 x 45 mm
Turning radius (over tyres)	3.31 m
Noise and vibration	
Noise at driving position (LpA)	76 dB
Environmental noise (LwA)	104 dB
Vibration to whole hand/arm	<2.50 m/s ²

Rough terrain load chart standard EN1459 B

Machine on tyres with forks

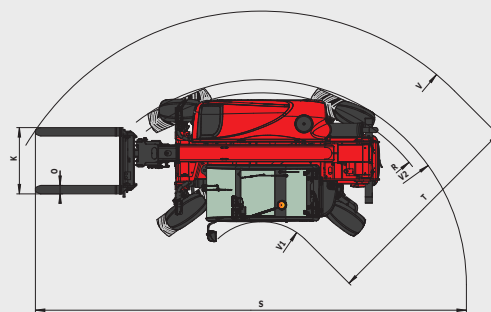
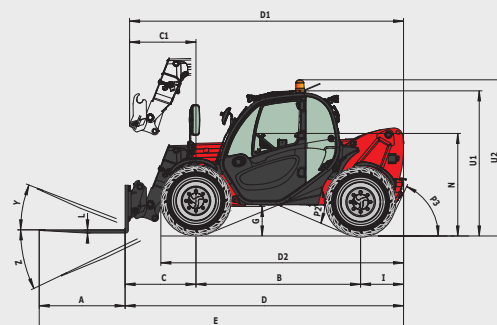
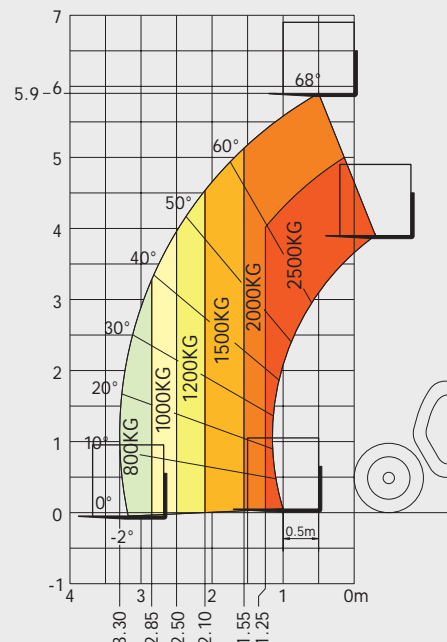

mm	
A	1200
B	2300
C	991
C1	928
D	3894
D1	3831

D2	3393
E	5094
F	1500
F1	1500
G	378
I	603
J	797

K	1015
L	45
N	1398
O	125
P2	45°
P3	65°
R	3033

S	6531
T	3475
U1	2000
U2	2167
V	4240
V1	765
V2	3310

W	1814
Y	12°
Z	117°

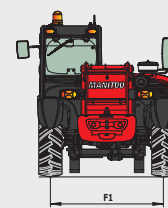
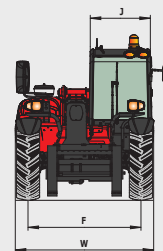

Your nearest **MANITOU** dealer:



Head office:
B.P. 249 - 430 rue de l'Aubinière - 44158 Ancenis Cedex - France
Tel: 00 33 (0)2 40 09 10 11 - Fax: 00 33 (0)2 40 09 10 97
www.manitou.com



facebook.com/manitou.official